



Hold-open device
Hold-open system

DORMA

TS 73 EMR
TS 73 EMF

The proven solution for controlled hold-open of fire and smoke check doors

Universal application capability, stable hold-open point and assured quality. The DORMA TS 73 EMF is a combination of hydraulic door closer and electro-magnetic hold-open unit. In conjunction with a smoke detection system (e.g. DORMA RMZ-K/S), the TS 73 EMF can be used as a hold-open system for fire and smoke check doors. Also available is the DORMA TS 73 EMR as an integrated system comprising hydraulic door closer, electro-magnetic hold-open device, power

supply unit and smoke detector. In the case of both systems, hold-open of the door is performed under electro-magnetic control. In the event of a fire, the door is reliably closed by the integral hydraulic closer. The closing cycle is also initiated by manual door operation or automatically in the event of a power failure.



Quality assured manufacture to DIN ISO 9001, EN 29001, BS 5750
Certified and verified by BSI Quality Assurance
Reg.-No. Q 6423, FM 10756

Benefits

For the trade

- Efficient stocking thanks to non-handed, modular system
- Range of arm assemblies and accessories to provide an ideal solution even for special applications.

For the fabricator/installer

- Easy to fix.
- Time-saving electrical connections.
- No adjustment of the hold-open point necessary.
- Optimum adaptability thanks to adjustable latching action.

For the specifier/architect

- Attractive, compact design.
- Wide range of applications.
- Hold-open possible between approx. 75° and 180°.

For the user

- To hold open, the door simply has to be opened to the required point and released.
- Free selection of the hold-open point (opening angles over 75°); variable at any time without the need for adjustment of setting controls.
- Convertible to free-swing door closer.

Data and features		TS 73 EMF			TS 73 EMR ¹⁾		
		4	EN		4	EN	
Closing force	Spring strength						
Standard doors ²⁾	≤ 1100 mm ≤ 1250 mm ≤ 1400 mm	●	●	●	●	●	●
Fire and smoke check doors ²⁾	≤ 1100 mm ≤ 1250 mm ≤ 1400 mm	●	●	●	●	●	●
Non-handed			●		●		
Arm	Standard		●		●		
	Slide channel		–		–		
Closing speed variable by valve			●		●		
Latching speed variable	by arm by valve		●		●		
Backcheck			–		–		
Delayed action			–		–		
Hold-open point variable (opening angles between 75° and 180°)			●		●		
Free-swing arm assembly			○		○		
Weight in kg			3,4		4,9		
Dimensions in mm	Length Overall depth Height		320 45,5 60		630 52 65,5		
Door closer compliant with EN 1154			●		●		
Hold-open device compliant with EN 1155			●		●		
Functions	Smoke detector Door release Power supply		– ● –		● ● ●		
Smoke detection	Scattered light principle Optical		– –		● ●		
Connection of other detectors	2-wire system Smoke switch		– –		● ●		
Total installed power (max.) for other detectors in W			–		5,7		
Indicators	Alarm – red LED Standby – green LED		– –		● ●		
Input voltage			24VDC ±15%		230VAC ±10%		
Output voltage			–		24VDC		
Power input max. in W			2		14,6		
Floating change-over contact, safety extra-low voltage (SELV)			–		24VAC/DC 2A		
Reset	Automatic with change-over to manual reset		–		●		
Test port for function test			–		●		
Connection terminals for external manual release			–		●		
Class of protection					IP20		
Ambient temperature range in °C			–		–15,+20		

● Yes – No ○ Option

¹⁾ Also available as slave unit for equipping double doors (no integral power supply unit or smoke detector)

²⁾ For applications involving particularly high or heavy doors, and doors which have to close against wind or draught conditions, the next larger closer size should be selected.



CERTIFIRE Approved
CF117
ITT120 IMM/MM240

Standard and optional functions

The **closing speed** of the DORMA TS 73 EMF and TS 73 EMR is infinitely variable by means of a valve. In addition, the **latching action** can be adjusted via the closer arm.

The **electro-magnetic hold-open device** is integrated in the hydraulic door closer. The hold-open point (available from an opening angle of 75°) is freely selectable. The door merely has to be opened to that angle required and then released. Depending on the door width and the size of the opening angle, a degree of fall-back of between 1° and 3° is possible.

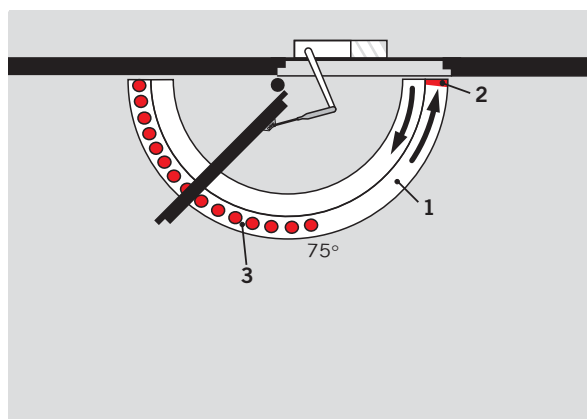

- 1 Infinitely variable closing speed
- 2 Infinitely variable latching action (adjustable at arm)
- 3 Hold-open range

Free-swing arm assembly (option)

Equipped with a free-swing arm assembly, the DORMA TS 73 EMF and TS 73 EMR can also be employed where doors are required to operate normally – functioning in the same way as doors without a door closer. If the door leaf is opened wide (min. 75°), the closer spindle is held in this position by the electro-magnetic hold-open device in the hydraulic closer body. However, the door can be freely operated by virtue of the free-swing function integrated in the arm.

In the event of a fire or power failure, the door is reliably and securely closed automatically by the hydraulic door closer.

Typical applications include fire and smoke check doors in senior citizen homes, homes for the disabled and hospitals etc.

Note:

In the case of double doors, the free-swing function may only be used on the active leaf.

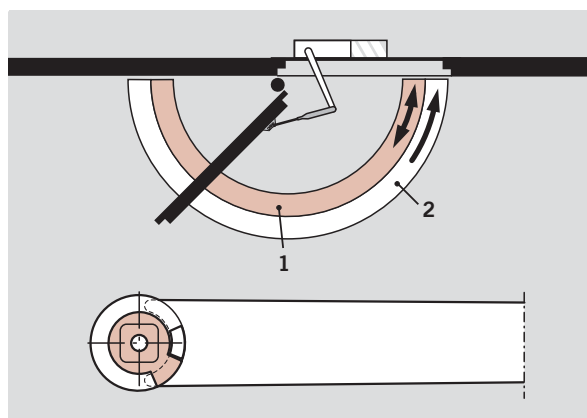

- 1 Free-swing range
- 2 Fully controlled closing (de-energised)

F Approval certification

TS 73 EMF

The DORMA TS 73 EMF has been approved as compliant with national building regulations by the German Institute for Building Technology DIBt, Berlin, in conjunction with the smoke detector systems DORMA RMZ-K/S, DORMA RMZ 2 and other reputable smoke detector systems. Acceptance inspection is mandatory. When using the TS 73 EMF fixed to the top jamb, approval certification is additionally required in conjunction with the fire and smoke check door concerned.

TS 73 EMR

The DORMA TS 73 EMR has been approved as a hold-open system by the German Institute for Building Technology DIBt, Berlin. Acceptance inspection is mandatory. Approval certification is additionally required in conjunction with the fire and smoke check door concerned.

Applications and installation

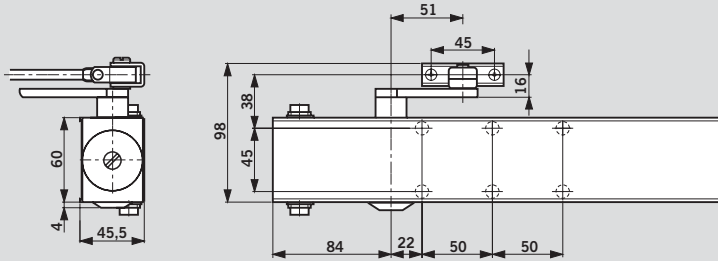

DORMA TS 73 EMF hold-open device

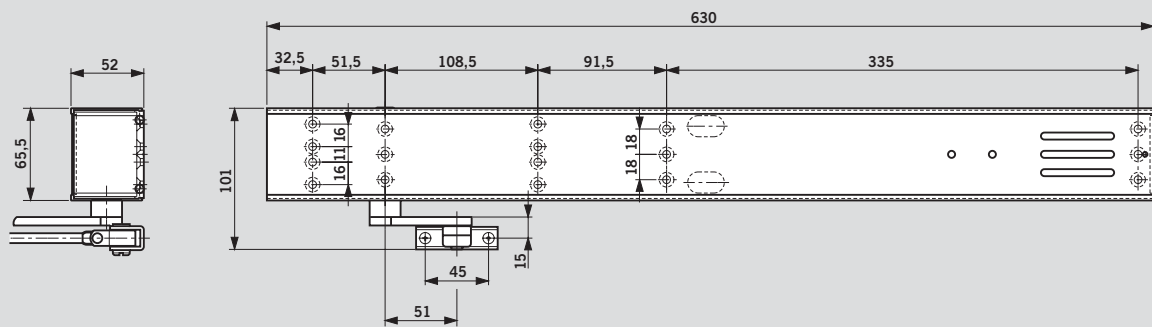

DORMA TS 73 EMR hold-open system

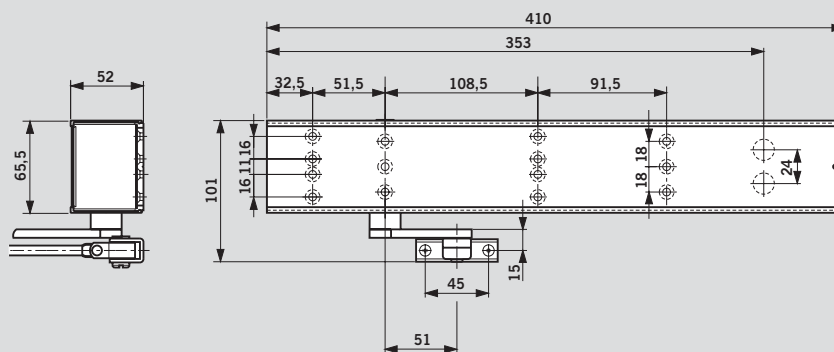

DORMA TS 73 EMF slave unit for hold-open system

Applications and installation

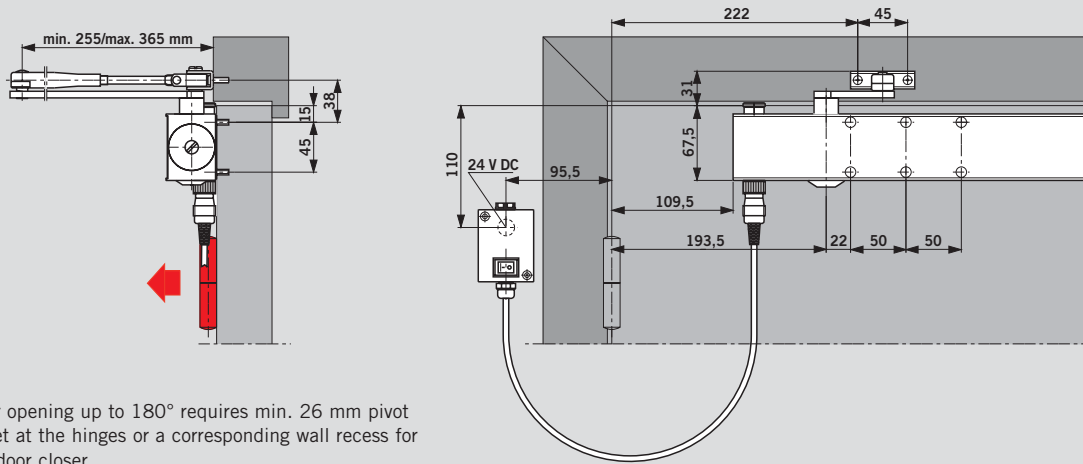

Door opening up to 180° requires min. 26 mm pivot offset at the hinges or a corresponding wall recess for the door closer.

Standard fixing of DORMA TS 73 EMF hold-open device (door leaf fixing). Example shows LH door (ISO 6); mirror arrangements apply to RH (ISO 5) doors.

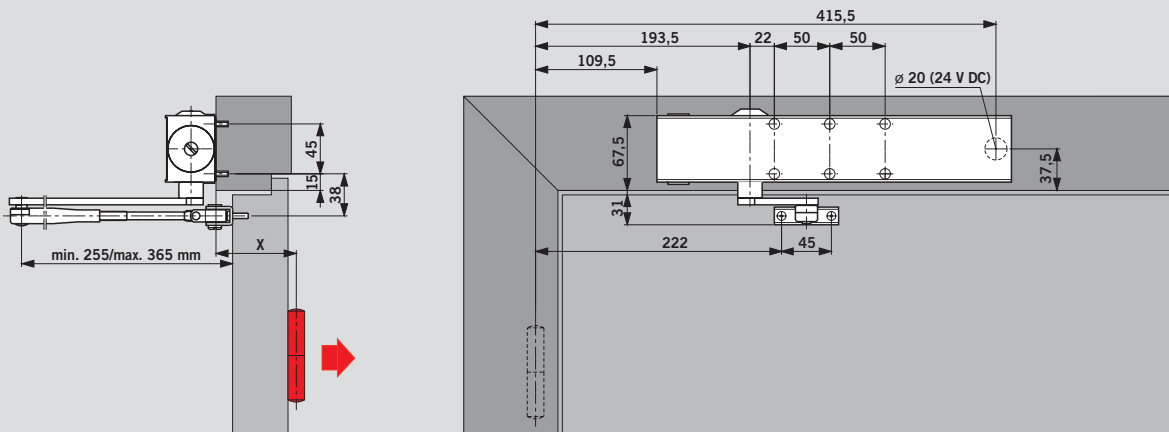

Door opening up to 180° with standard arm only possible where $X \leq 70$ mm

Top jamb fixing of DORMA TS 73 EMF hold-open device (frame installation).

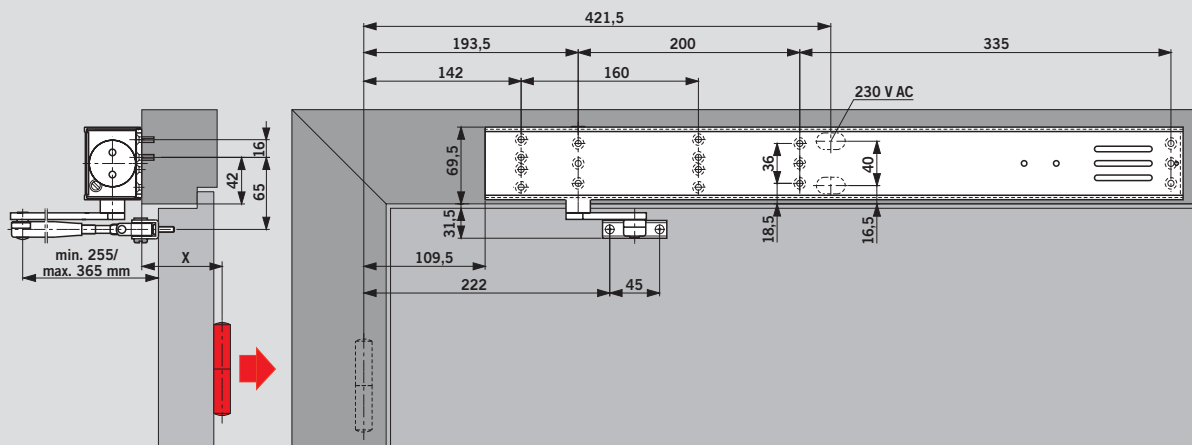

Door opening up to 180° with standard arm only possible where $X \leq 70$ mm

DORMA TS 73 EMR. hold-open system. Example shows RH door (ISO 5); mirror arrangements apply to LH (ISO 6) doors.

Mounting backplate

For pull and push side fixing.

For mounting the DORMA TS 73 EMF to fire and smoke check doors and also doors in which no direct fixing is possible; with hole group per Supplement 1 to EN 1154.

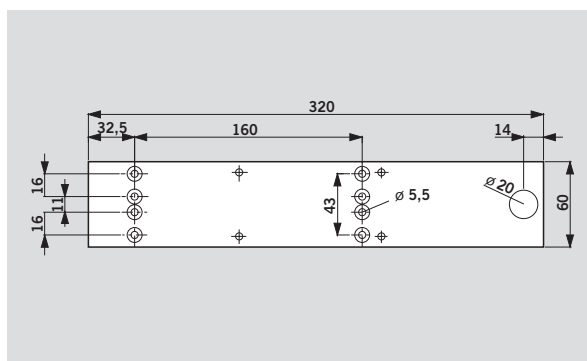
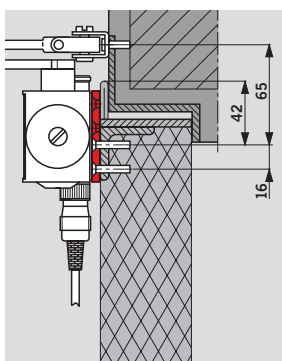

Upstand bracket

For pull-side installation of the arm on particularly narrow door frames.

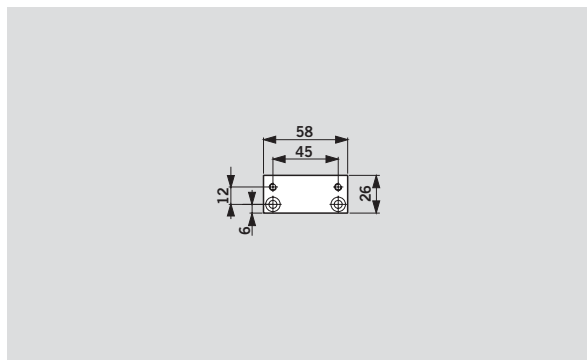
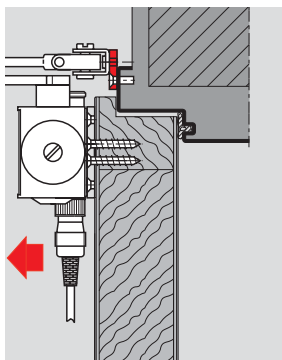

Extended adjustable arm

For push side fixing.
For adapting the DORMA TS 73 EMF/EMR to door sets with frame reveal depths between 70 and 135 mm.

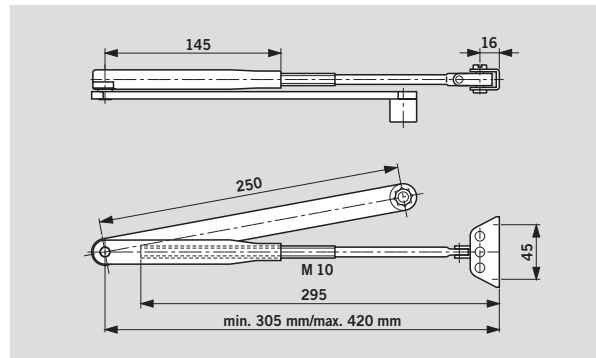
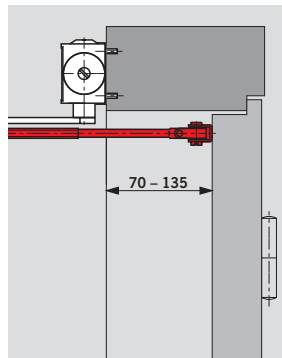

Extended arm assembly

For push side fixing.
For increasing the door opening to 180° in door sets with a frame reveal depth of max. 70 mm and where $X < 70$ mm.

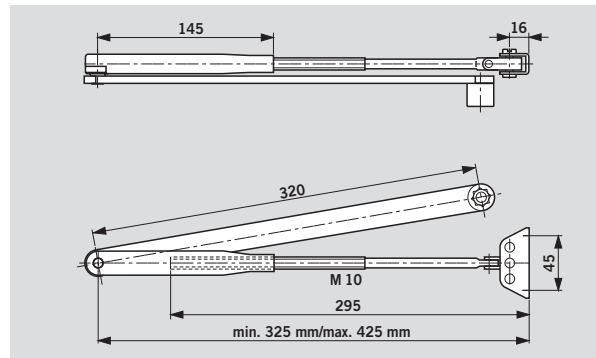
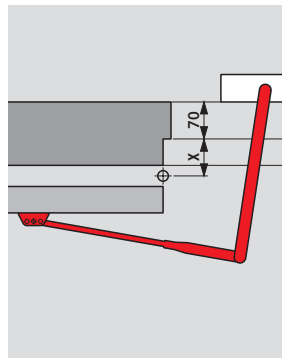

DORMA HT manual switch

According to the code of practice for hold-open systems issued by the DIBt, Berlin, a manual release switch must be installed in the case of free-swing door closers.

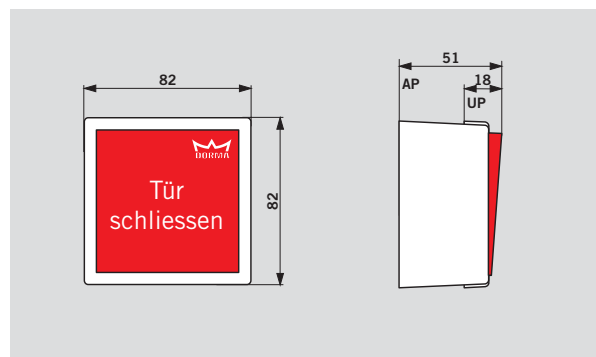
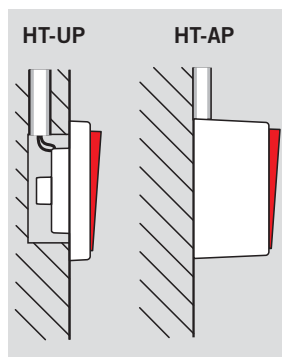

DORMA TS 73 EMF + RMZ-K + 2x RM

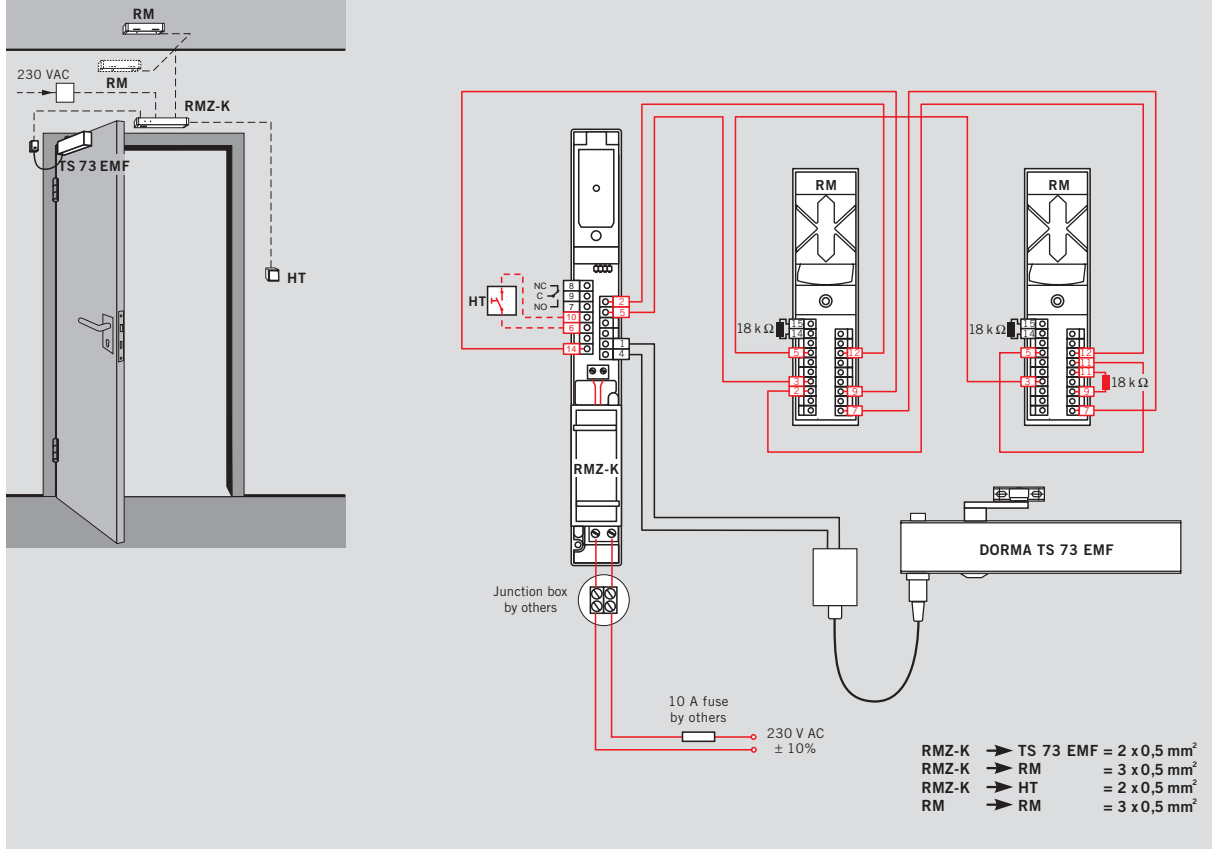

DORMA TS 73 EMR + 2x RM

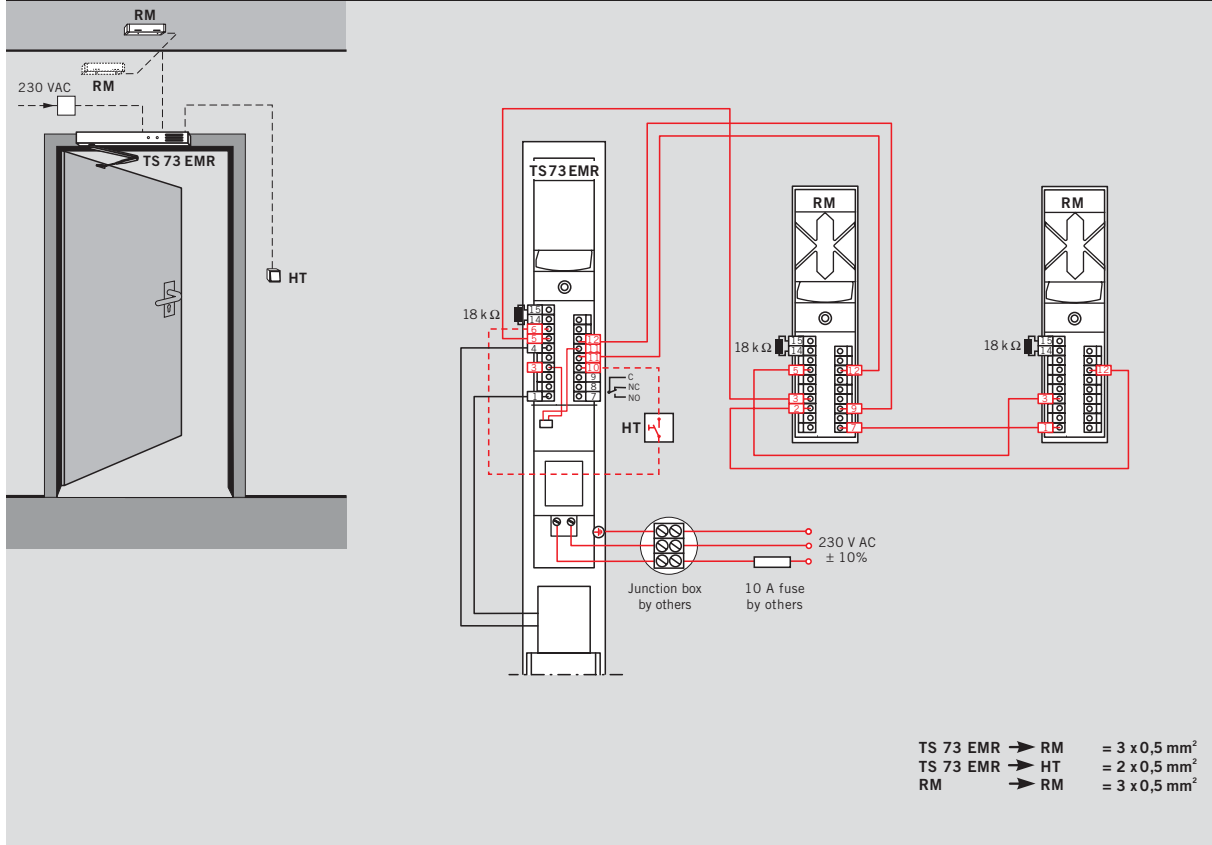

The use of hold-open systems is subject to special regulations based on official approval requirements. These relate in particular to the final inspection (acceptance), continuous monitoring and maintenance.

The regulations and instructions provided below are intended as an aid, pursuant to statutory regulations that apply e.g. in Germany, to ensure that all participants are properly informed of the most important requirements that relate to the installation and operation of hold-open systems.

Further information can be found in the following documents:

- Richtlinien für Feststellanlagen des Deutschen Instituts für Bautechnik, Berlin
[Code of practice relating to hold-open systems issued by the German Institute for Building Technology, Berlin]

- General building regulations pertaining to the approval of the hold-open system concerned
- EN 1155

1. General

1.1 In the case of fire doors (and similar shutters/closures/barriers) that are held open by hold-open systems, the sweep area necessary for the closing operation must be kept constantly clear. This area must be clearly identified by lettering, floor markings or similar. Where necessary, structural measures must also be implemented to ensure that cables, leads, lines,

pipes, stored/deposited goods or components (e.g. false ceilings or other overhead items/elements) are reliably prevented from falling into the sweep area.

1.2 Wherever possible, smoke detectors should be used for hold-open systems. For hold-open systems for fire doors in emergency escape routes, smoke detectors must be used.

1.3 Each hold-open device must also be capable of being released by hand, without adversely affecting the functional capabilities of the automatic release device. In the case of door closers with electro-magnetic hold-open, the manual release may be performed by a small tug applied to the door leaf. If holding electro-magnets or free-swing door closers are

used, a pushbutton must be provided to facilitate manual release.

The manual release push-buttons employed for this purpose must be red and carry the wording "Close Door" or equivalent. The pushbutton must be located in the immediate vicinity of the door and must not be concealed by the door when this is held open.

2. Final inspection (acceptance)

2.1 In Germany and countries governed by DIN regulations: Following on-site installation of the operable hold-open system, its functional integrity and quality of installation must be confirmed by an acceptance inspection procedure. The acceptance inspection may only be performed by skilled personnel of manu-

facturers of monitoring and/or hold-open devices, skilled personnel authorized by same, or skilled personnel from an accredited inspection agency.

2.2 In Germany and countries governed by DIN regulations: Once the acceptance inspection has been successfully completed, the operator shall permanently fix on the wall

in the immediate vicinity of the door, a plate supplied by the manufacturer of the hold-open system measuring 105 mm x 52 mm and carrying the inscription
Hold-open system
Inspected by... (company logo with month and year of acceptance inspection) or equivalent

2.3 The operator is to be provided with a certificate detailing the successful acceptance inspection; this certificate must be retained by the operator.









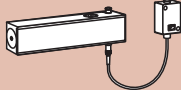
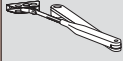

3. Periodic surveillance

3.1 The hold-open system must be kept by the operator in a constantly good operating condition, and inspected at least once a month to ensure that it is functioning properly.

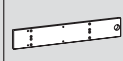
3.2 In addition, the operator is obliged at least once a year, or at shorter intervals if specified in the approval certificate, to inspect all the devices to ensure that they are operating and interacting properly and without fault,

and to carry out or instigate adequate maintenance. The associated test, inspection and the maintenance work may only be performed by an expert or an appropriately trained person.

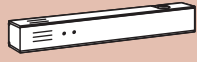
3.3 The scope, result and time of the periodic inspection are to be recorded. These records must be retained by the operator.

Standard equipment and optional accessories							
TS 73 EMF hold-open device Pull-side door leaf fixing 	Standard arm  <input type="checkbox"/> 7540xx00	Free-swing arm  <input type="checkbox"/> 530005xx	Extended adjustable arm  <input type="checkbox"/> 7540xx01	Extended arm assembly  <input type="checkbox"/> 7540xx34	Mounting backplate  7300xx10	Upstand bracket  830014xx	Manual switch HT-UP  35901531 HT-AP  35901532
Spring strength EN 4 ■ 530101xx	<input type="checkbox"/>	<input type="checkbox"/>			#	#	#
Spring strength EN 5 ■ 530401xx	<input type="checkbox"/>	<input type="checkbox"/>			#	#	#
Spring strength EN 6 ■ 530701xx	<input type="checkbox"/>	<input type="checkbox"/>			#	#	#
TS 73 EMF hold-open device Push-side top jamb fixing 							
Spring strength EN 4 ■ 531101xx	<input type="checkbox"/>	<input type="checkbox"/>	<input type="checkbox"/>	<input type="checkbox"/>	#		#
Spring strength EN 5 ■ 531401xx	<input type="checkbox"/>	<input type="checkbox"/>	<input type="checkbox"/>	<input type="checkbox"/>	#		#
Spring strength EN 6 ■ 531701xx	<input type="checkbox"/>	<input type="checkbox"/>	<input type="checkbox"/>	<input type="checkbox"/>	#		#
TS 73 EMR hold-open system 							
Spring strength EN 4 ■ 541201xx	<input type="checkbox"/>	<input type="checkbox"/>	<input type="checkbox"/>	<input type="checkbox"/>			#
Spring strength EN 5 ■ 541301xx	<input type="checkbox"/>	<input type="checkbox"/>	<input type="checkbox"/>	<input type="checkbox"/>			#
Spring strength EN 6 ■ 541401xx	<input type="checkbox"/>	<input type="checkbox"/>	<input type="checkbox"/>	<input type="checkbox"/>			#
Slave unit for TS 73 EMR hold-open system 							
Spring strength EN 4 ■ 540901xx	<input type="checkbox"/>	<input type="checkbox"/>	<input type="checkbox"/>	<input type="checkbox"/>			#
Spring strength EN 5 ■ 541001xx	<input type="checkbox"/>	<input type="checkbox"/>	<input type="checkbox"/>	<input type="checkbox"/>			#
Spring strength EN 6 ■ 541101xx	<input type="checkbox"/>	<input type="checkbox"/>	<input type="checkbox"/>	<input type="checkbox"/>			#

Order No. **Colour** **xx**
 ■ = Closer body separate Silver 01
 = Arm assembly separate Special colour 09
 # = Optional accessory

DORMA TS 73 EMF specification text

Hold-open device with electro-hydraulic hold-open function and integral pressure compensation feature for stable, infinitely variable and temperature-immune hold-open positions at door opening angles between 75° and 180°. Closing speed and latching action infinitely variable. Non-handed. Operating voltage 24 V DC. General building regulations approval issued by DIBt, Berlin, for use in hold-open systems. Acceptance inspection mandatory.

Installation

- Door leaf fixing
- Top jamb fixing

Spring strength

- EN 4
- EN 5
- EN 6

Arm type

- Standard
- Free-swing
- Extended adjustable arm
- Extended arm assembly

Accessories

- Mounting backplate
- Upstand bracket
- Manual switch

Colour

- Silver
- Special colour _____
(sim. to RAL ____)

Make

DORMA TS 73 EMF

 TS73EMF

DORMA TS 73 EMR specification text

Hold-open device with electro-hydraulic hold-open function and integral pressure compensation feature for stable, infinitely variable and temperature-immune hold-open positions at door opening angles between 75° and 180°. With integral power supply unit and smoke detector. Closing speed and latching action infinitely variable. Non-handed. Connections for further detectors, external manual release device and floating alarm contact. Designed for 230 V AC power supply, operating voltage 24 V DC. Generally approved as hold-open system per building regulations by DIBt, Berlin. Acceptance inspection mandatory.

- Slave unit for double doors, without power supply unit and smoke detector. Operating voltage 24 V DC

Spring strength

- EN 4
- EN 5
- EN 6

Arm type

- Standard
- Free-swing
- Extended adjustable arm
- Extended arm assembly

Accessories

- Manual switch

Colour

- Silver
- Special colour _____
(sim. to RAL ____)

Make

DORMA TS 73 EMR

 TS73EMR

Division Door Control worldwide

www.dorma.com

Central Europe

DORMA GmbH + Co. KG
Breckerfelder Str. 42-48
D-58256 Ennepetal
Tel. +49 23 33/7 93-0
Fax +49 23 33/7 93-495

Scanbalt

DORMA Danmark A/S
Sindalvej 6 - 8
DK-2610 Rødovre
Tel. +45 44/54 30 00
Fax +45 44/94 95 04

Australia

DORMA Door Controls Pty. Ltd.
52 Abbott Road
Hallam/Victoria 3803
Australia
Tel. +61 3/97 96 35 55
Fax +61 3/97 96 39 55

South Africa

DORMA Door Controls (Pty.) Ltd.
Kings Court, 4A Mineral Crescent
ZA-2000 Crown/Gauteng
Johannesburg
Tel. +27 11/8 30 02 80
Fax +27 11/8 30 02 91

Emerging Markets

DORMA GmbH + Co. KG
Breckerfelder Str. 42-48
D-58256 Ennepetal
Tel. +49 23 33/7 93-0
Fax +49 23 33/7 93-495

South America

DORMA Sistemas de Controles
para Portas Ltda.
Av. Piracema, 1400
Centro Empresarial Tambore
CEP 06400 Barueri/
São Paulo, Brasil
Tel. +55 11/41 91 32 44
Fax +55 11/41 91 21 93

Far East

DORMA Door Controls Pte. Ltd.
No. 2 Jalan Terusan,
Jurong
Singapore 619285
Tel. +65 62 68/76 33
Fax +65 62 65/79 14

South-East Europe

DORMA AUSTRIA GmbH
Pebering Strass 22
A-5301 Eugendorf
Tel. +43 62 25/2 84 88
Fax +43 62 25/2 84 91

France

DORMA France S.A.S.
Europarc
42, rue Eugène Dupuis
F-94046 Créteil
Tel. +33 1/41 94 24 00
Fax +33 1/41 94 24 01

South Europe

DORMA Italiana S.r.l.
Via. A. Canova 44/46
I-20035 Lissone (MI)
Tel. +39 039/24 40 31
Fax +39 039/24 40 33 10

Gulf

DORMA Gulf Door Controls FZE
Jebel Ali Free Zone,
Roundabout 8,
Unit VC 02
Dubai, United Arab Emirates
Tel. +971 48/83 90 14
Fax +971 48/83 90 15

DORMA Ibérica, S.A.
Camino San Martin de la Vega, 4
E-28500 Arganda del Rey
(Madrid)
Tel. +34 91/8 75 78 50
Fax +34 91/8 75 78 81

UK/Ireland

DORMA UK Ltd.
Door Controls Division
Wilbury Way
GB-Hitchin
Hertfordshire SG4 0AB
Tel. +44 14 62/47 76 00
Fax +44 14 62/47 76 01

North America

DORMA Architectural Hardware
DORMA Drive, Drawer AC
Reamstown, PA 17567
Tel. +1-800-523-8483
Fax +1-800-274-9724

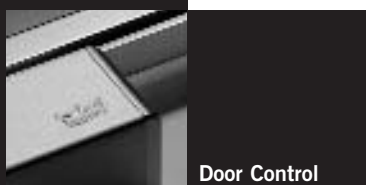

Door Control

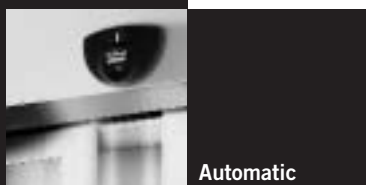

Automatic

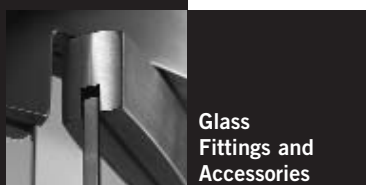

Glass
Fittings and
Accessories

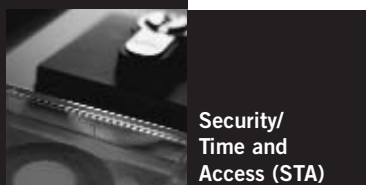

Security/
Time and
Access (STA)

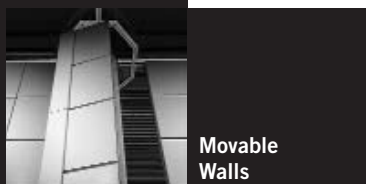

Movable
Walls

